



RETROFIT INSULATION in WOOD ROOFS

ALASKA
BUILDING
RESEARCH
SERIES
HCM-01552

Introduction

This publication is one of nine that has been translated from Norwegian. They are taken from a series of publications produced by the Norwegian Building Research Institute (NBI) series, "Byggedetaljer," which literally translated means "building details." It is hoped that Alaskan builders will be able to glean useful ideas from these publications. The translations were done by Dr. Nils Johanson and Richard D. Seifert of the University of Alaska Fairbanks with the cooperation and permission of NBI, Oslo, Norway. The financial support for the translations and printing came through the Alaska Department of Community and Regional Affairs, from USDOE Grant DE-FG06-80CS6908. The publications use the original index code of the Norwegian "Byggedetaljer" series so that specific translations can be directly cited. All questions on these translations should be directed to Richard D. Seifert, Cooperative Extension Service, P.O. Box 756180, University of Alaska Fairbanks, Fairbanks, Alaska 99775-6180. Phone: 907-474-7201

0 GENERAL

- 01 This bulletin describes how wooden roofs can be retrofitted with additional insulation to improve the thermal efficiency of the house. Suggestions are provided for suitable ways to retrofit wooden roofs, the various insulation methods available are outlined, and U values (heat transmission coefficient) for various insulation thicknesses are given.
- 02 Retrofitting insulation in roofs with poor thermal insulation (high U value) reduces the heating cost, reduces the tendency for ice formation on the roof, and provides a more comfortable internal climate. In order to estimate the appropriate insulation thickness and determine the best insulation method, consider the climate, construction, architectural design, need for replacement of internal ceiling, historical value of the building, and the types of surrounding buildings.
- For many houses it is especially economical to insulate the ceiling or roof. The ceiling often has a larger surface area than the walls and it is usually simpler to improve. Retrofitting insulation in roofs must, however, be considered along with the possible need for insulating floors and walls and improvement or replacing poor windows.
- 03 Ventilated wooden roofs are usually constructed in the following order (from the outside to the inside):
 - a. Roof cover (typically shingles)
 - b. Air space
 - c. Wind tight cover (building cardboard or wind tight sheathing)
 - d. Thermal insulation
 - e. Air and vapor barrier (polyethylene)
 - f. Ceiling finish materialThe structural system varies.

Older roofs are as a rule not constructed in this manner. The insulation must therefore fit the actual construction of the existing roof and be coordinated with other work that is necessary or desirable to do at the same time. To avoid damage or poor results, it is important to consider that the retrofit insulation and ceiling will alter the temperature conditions in the roof. Parts of the roof that were warm before can be cold, intensifying condensation problems. The danger of condensation is greatest above rooms with high relative humidity, such as bathrooms, kitchens, or rooms which are cyclically heated and have insufficient ventilation. In houses with good ventilation and low relative humidity, there is little danger of condensation, provided no air leaks from the living area into the roof cavity.

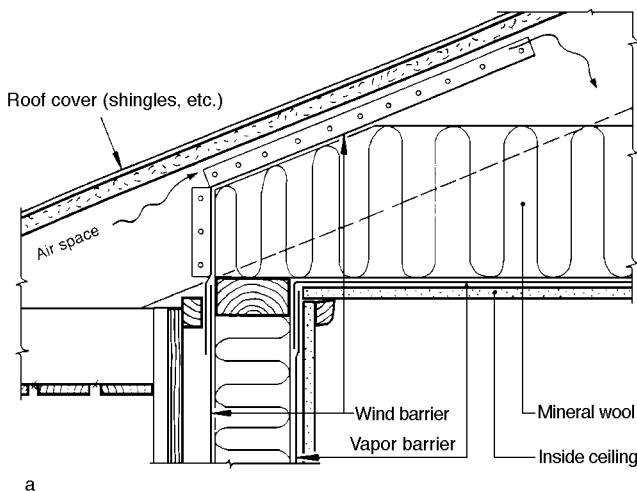

a

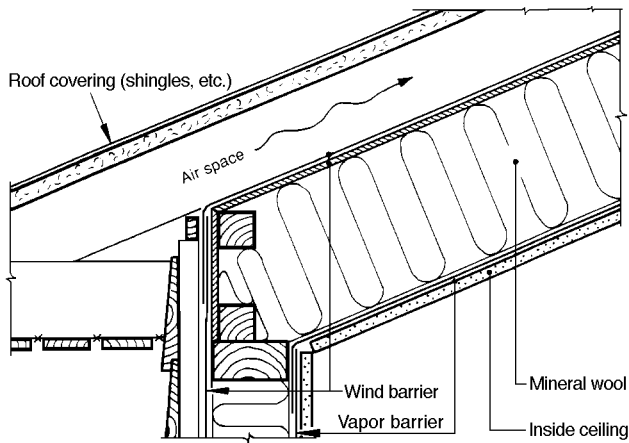

b

Figure 03
Correctly constructed ventilated (cold) wooden roof
a) w/ horizontal ceiling
b) w/ cathedral ceiling

1.0 MATERIALS

1.1 Wood materials

The wood must be dry, straight, and without cracks. Wood that will be subjected to moisture for long periods should be preserved.

1.2 Thermal Insulation

Use rigid foam plastic boards or fiberglass batts. The standard width, 570 mm (23 in), fits between nailing boards and beams or rafters that are 600 mm (24 in) center to center. The length can vary from 870 mm (34 in), fitting between nail boards that are 900 mm (36 in) center to center, to 1200 mm (48 in) and longer. Use fiberglass without paper backing. Hollow spaces can also be filled by blowing in shredded mineral wool.

1.3 Windbarrier

Sealing against wind penetration now done with Tyvek® or equivalent air barrier materials.

1.4 Vapor barrier

As a diffusion break, use polyethylene plastic or foil-covered cardboard with a vapor diffusion number of $0.01 \text{ g/m}^2 \text{ h mm mercury}$. This is equivalent of a material with a "perm" rating of 1.0 or less. For polyethylene, the recommended thickness is at least 6 mil so that the foil will not be torn during construction.

2.0 EXECUTION OF WORK

Table 2 shows U values for various roof types with retrofit insulation with mineral wool. Details of older roof construction can vary depending upon local building customs and the age of the building. The given U values are approximate.

2.10 Attic joists

An example of joists with insulation is shown in figure 2.10.

2.11 Insulating from the outside (topside) will cause minimal changes on the inside and will allow continuous insulation over the entire roof. Avoid reducing the attic ventilation, and insure that there are no air leaks from the warm side of

Table 2

U values (W/m²·°C) (BTU/hr-ft²·°F) for roofs using different methods of retrofit.

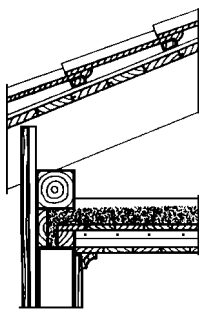
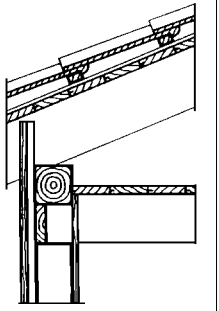
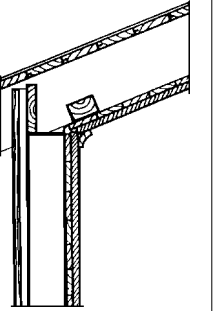
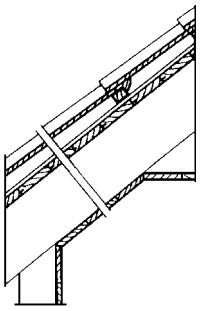
Insulation method	Mineral Wool thickness in mm (in)	 Open beams w/ various fill insulation in cold attic*	 Beams w/o fill insulation in cold attic	 Roof w/sloped interior ceiling	 Roof w/ partially warm attic
As before	—	1.46	2.54	1.40	2.09
Insulation from the outside	50mm (2 in) 100mm (4 in) 150mm (6 in)	0.60 0.37 0.26	0.67 0.39 0.28	— — 0.33	— — —
Insulation from the inside	50mm (2 in) 100mm (4 in) 125mm (5 in) 150mm (6 in)	0.54 0.27 0.37 —	— 0.42 0.29	0.52 0.35 —	— — —
Pneumatically placed mineral wool	50mm (2 in) 100mm (4 in) 150mm (6 in)	0.66 — —	— — —	— — 0.33	— — —

* 50 mm clay

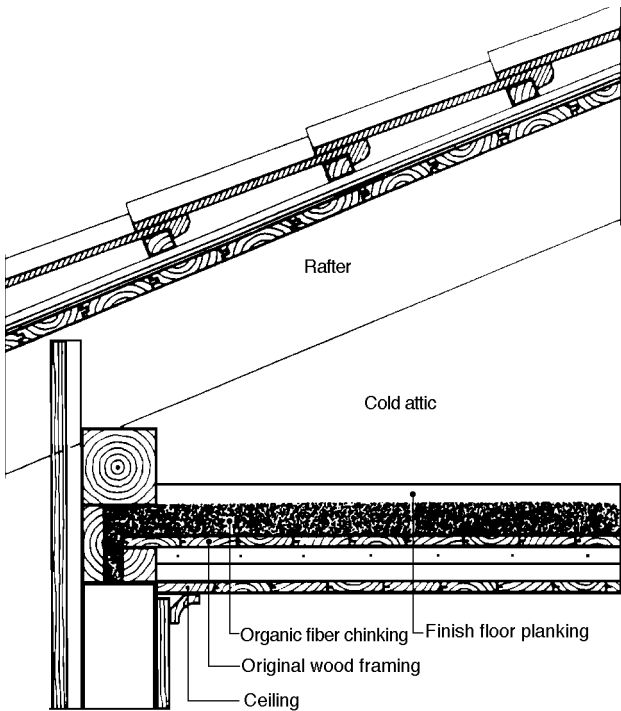

Figure 2.10 Attic beams with organic fiber chinking (the space between the beams forming the attic floor).

the ceiling. The original insulation between the joists can either be removed and replaced with mineral wool which will fit the joist spacing, or mineral wool can be placed over the existing insulation. In either case, consider whether the ceiling is sufficiently air and vapor tight to avoid condensation. Carefully seal areas where perforations occur. If there is doubt about the integrity of the internal sealing, install a new vapor barrier and a ceiling (Figure 2.11).

Insulation can be placed directly on the attic floor if it is not being used. It is advisable, however, to install a walkway over the insulation along the middle of the attic.

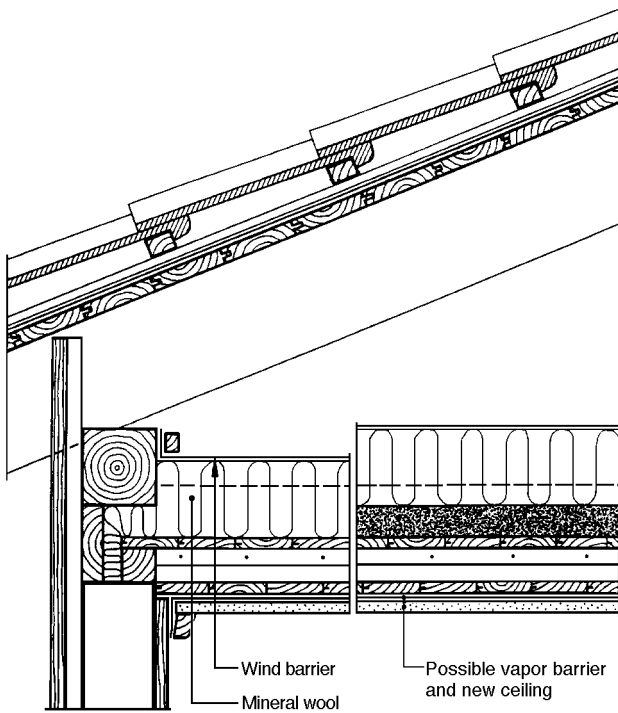

Figure 2.11
Attic floor joists insulated from above.

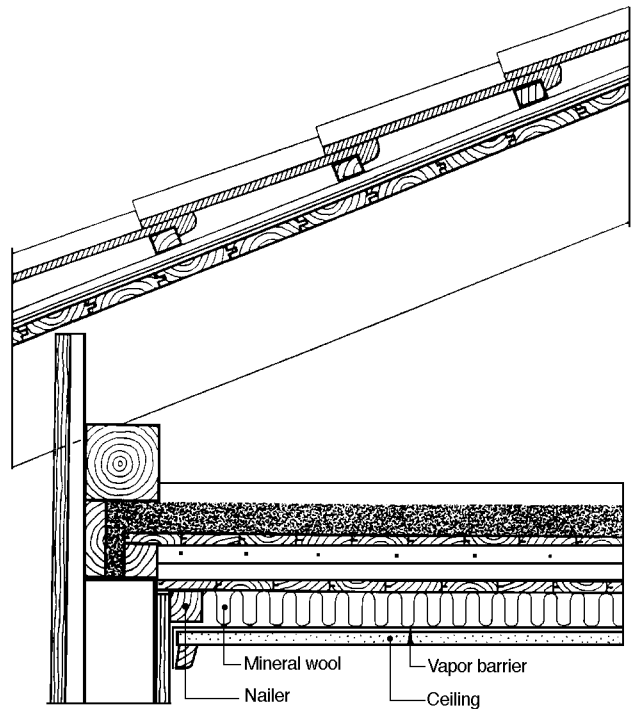

Figure 2.12
Attic floor insulated from below.

2.12 If insulation is being done one room at a time, or if a new internal ceiling is being installed, mineral wool can be placed between nailers 600 mm (24 in) center to center. The nailers should be attached directly to the old ceiling. Finally, a new vapor barrier with sealed joints and a new ceiling should be installed (Figure 2.12).

2.13 If the space between the existing ceiling and the attic is at least 50 mm (2 in), it may be possible to blow mineral wool into the hollow space (Figure 2.13). Before doing so, however, an expert should look over the condition of the roof to avoid damage. The pneumatic placement of mineral wool must be done by special companies employing trained professionals.

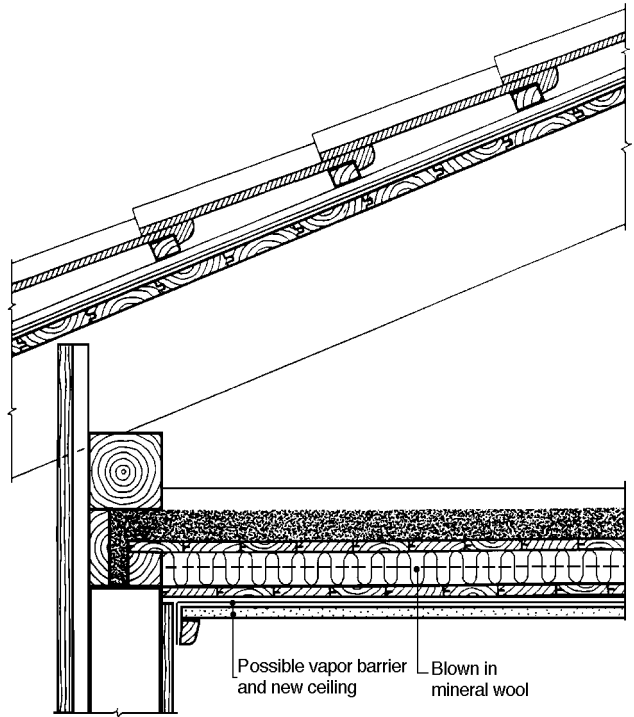

Figure 2.13
Attic floors insulated with blown in mineral wool. If the existing ceiling is sufficiently tight with respect to air leaks, a new vapor barrier is not necessary.

2.20 Attic floor (without insulation)

An example of a floor with tongue and groove boards is shown in Figure 2.20.

2.21 If exposed beams are desired, the attic floor can be insulated on the top side. First, install a vapor barrier over the entire ceiling. The vapor barrier must be joined and sealed tightly along the outer walls. If a floor is needed, install nailers 600 mm (24 in) center to center and place mineral wool between them. If the attic will not be used, the mineral wool can be placed directly on the attic floor. Install an air barrier over the insulation. See point 2.11.

2.22 The floor can be insulated from the underside by placing mineral wool in the space between the floor joists. Sheets or batts of mineral wool must be cut to fit so that they are 20 mm (1 in) wider than the space between the joists. If this is done properly, the mineral wool will stay in the space between the beams until a vapor barrier and ceiling is installed.

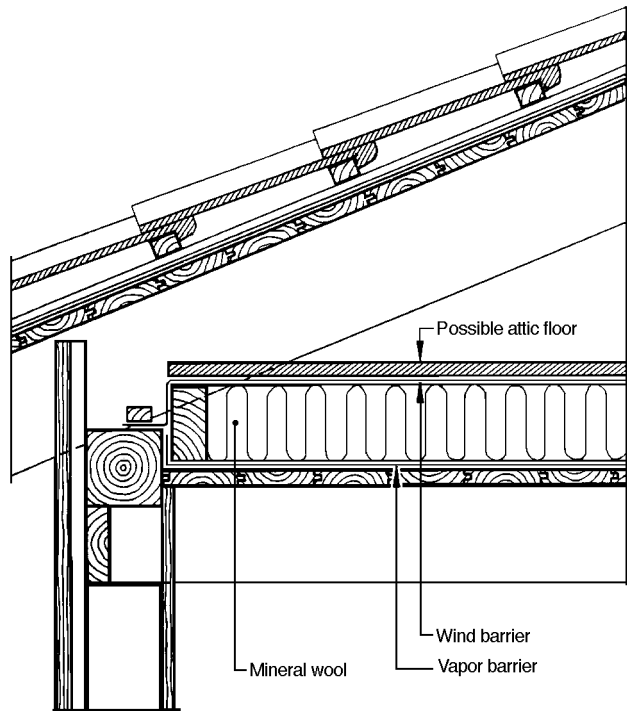

Figure 2.21
Beams without organic fiber chinking insulated from above.

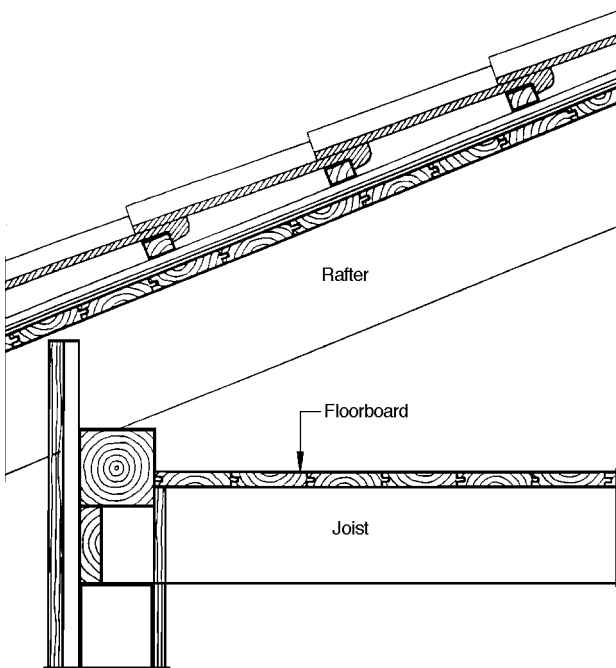

Figure 2.20
Attic floor with no insulation

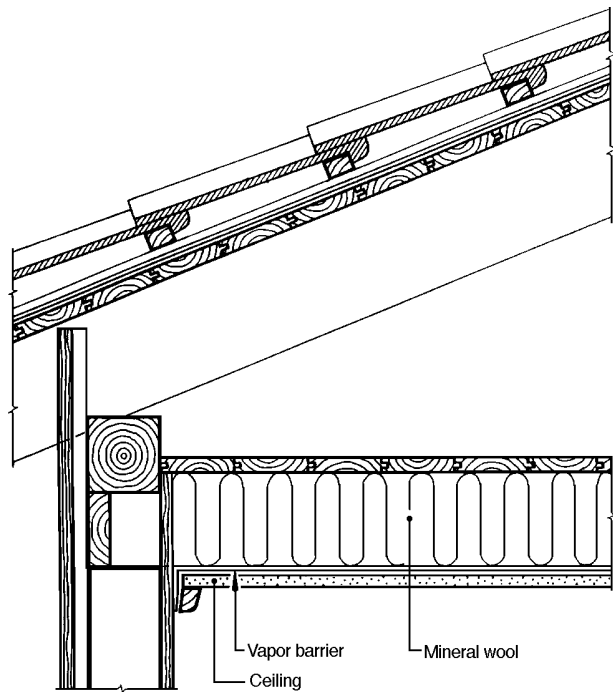

Figure 2.22
Attic floor insulated from below.

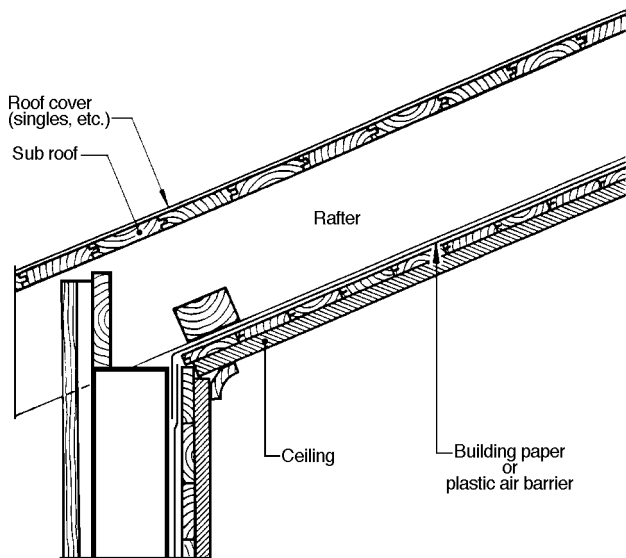

Figure 2.30

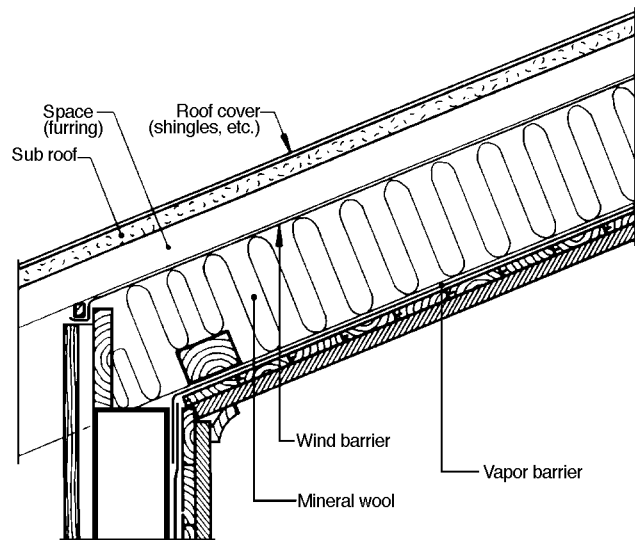

Figure 2.31
Roof with cathedral ceiling insulated from above.

2.30 Roofs with cathedral ceiling

An example of an uninsulated roof with cathedral ceiling is shown in Figure 2.30.

2.31 Special design considerations for preventing snow melt are needed when adding insulation from the outside of the roof. The old roof must be opened from above and new mineral wool must be placed in the area between the rafters. A wind barrier must be installed over the mineral wool. The new roofing must then be shimmed up 50 to 100 mm (2 to 4 in) to ensure sufficient ventilation (Figure 2.31).

2.32 When insulating from the inside, the mineral wool must be placed between nailers 600 mm (24 in) center to center. The nailers should be fastened directly to the old ceiling. Install a vapor barrier with sealed joints, and finally, a new ceiling.

2.33 By building up a new roof on the old roof it is possible to insulate by blowing mineral wool into the hollow space. See Figure 2.33 and Point 2.13.

2.40 Roof over an attic space in 2 story house. An example of such roof construction is shown in Figure 2.40.

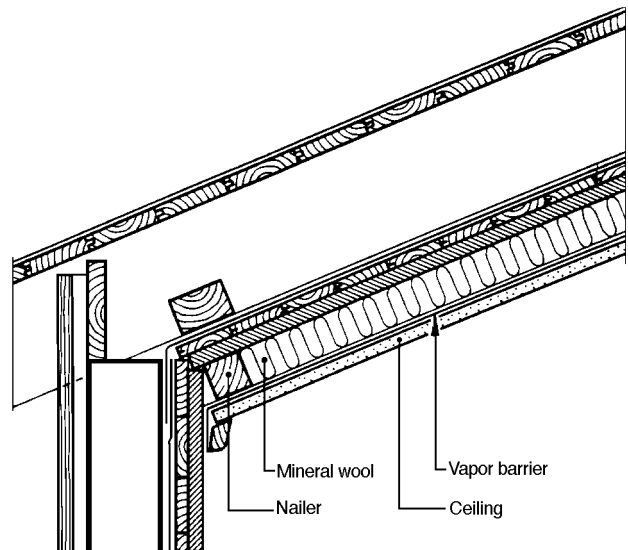

Figure 2.32
Roof with cathedral ceiling insulated from below.

2.41 In older buildings, when insulating the roof between a knee wall and a horizontal ceiling, fill the entire hollow area between the internal paneling and the roof with mineral wool. It may, however, be difficult to place the insulation. In many cases it must be threaded in from above or pushed up from below. In other cases it is necessary to break up the internal paneling or wall covering to gain access. If walls are damaged, install a vapor barrier before a new internal covering is put on.

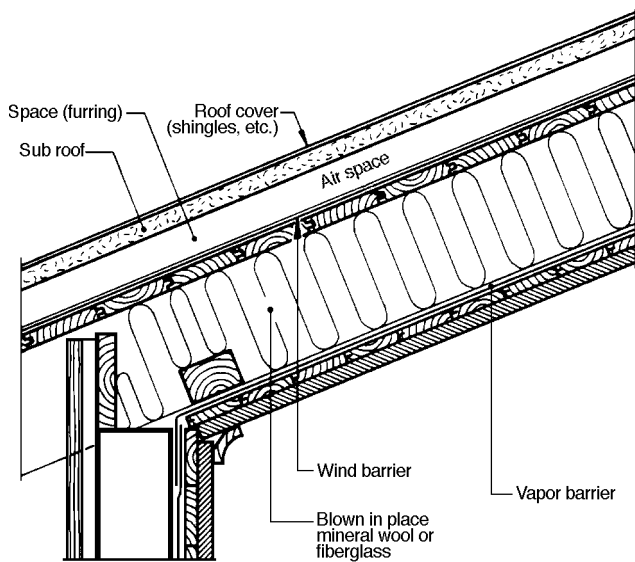

Figure 2.33
Roof with sloping ceiling insulated with pneumatically placed mineral wool.

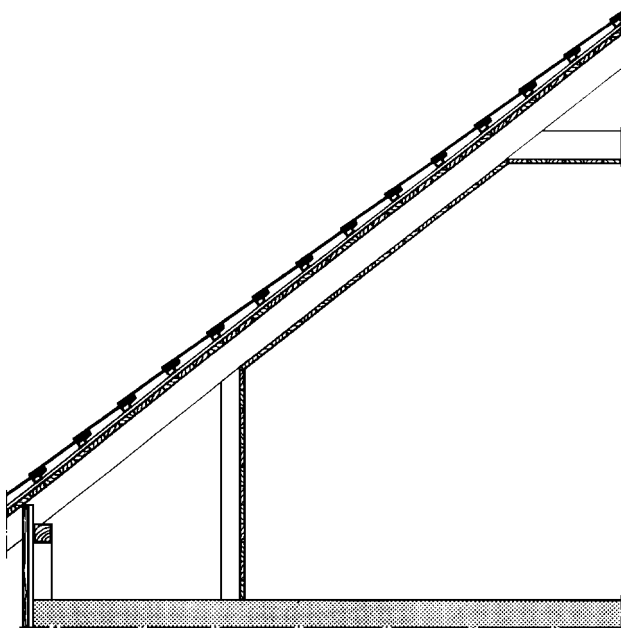

Figure 2.40
Roof over attic or finished room in 2 story house

2.50 Joists: To avoid reduced insulation performance, drafts, and condensation it is important that all wind and vapor barriers are tightly sealed against the adjoining framing. The joints must always be pressed between two solid backing layers. The mineral wool must completely fill the space into which it is placed.

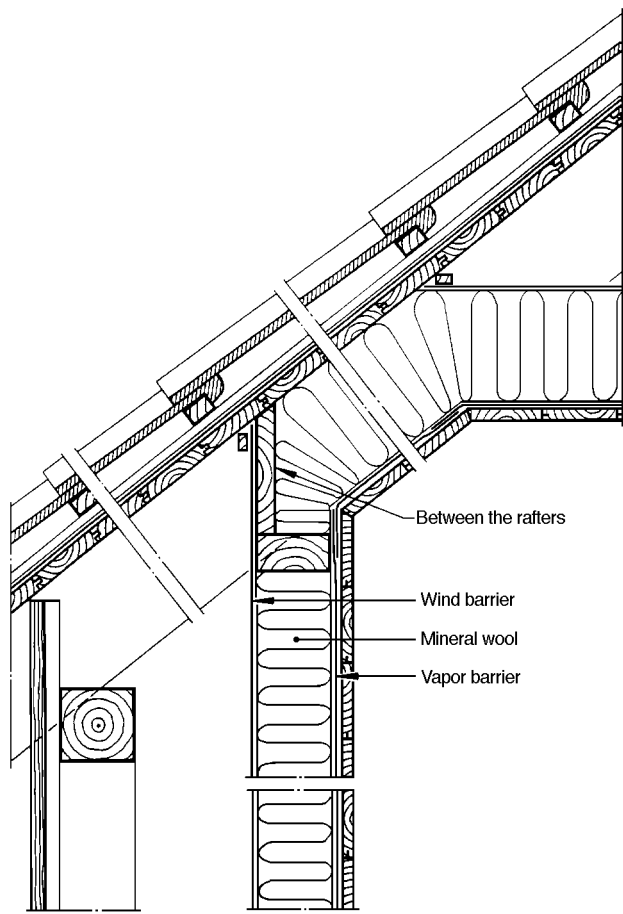

Figure 2.41
Insulation of room in a 2 story house.

3.0 REFERENCES

3.10 This bulletin was developed and edited by Knut I. Edvardsen. The editing was completed in September 1977.

Translated into English by Dr. Nils Johansen and Richard D. Seifert, University of Alaska Fairbanks, November 1989.

Revised and reviewed February 1997, by Axel R. Carlson, professor emeritus, University of Alaska Fairbanks and Dr. John P. Zarling, Department of Mechanical Engineering, University of Alaska Fairbanks.

Visit the Cooperative Extension Service website at www.uaf.edu/ces
and Rich Seifert's homepage at www.uaf.edu/coop-ext/faculty/seifert



8/91/RS/500

Reprinted April 2006

The University of Alaska Fairbanks Cooperative Extension Service programs are available to all, without regard to race, color, age, sex, creed, national origin, or disability and in accordance with all applicable federal laws. Provided in furtherance of Cooperative Extension work, acts of May 8 and June 30, 1914, in cooperation with the U.S. Department of Agriculture, Anthony T. Nakazawa, Director, Cooperative Extension Service, University of Alaska Fairbanks.

The University of Alaska Fairbanks is an affirmative action/equal opportunity employer and educational institution.