



RETROFIT INSULATION in EXISTING WOODEN WALLS

ALASKA
BUILDING
RESEARCH
SERIES
HCM-01554

Introduction

This publication is one of nine that has been translated from Norwegian. They are taken from a series of publications produced by the Norwegian Building Research Institute (NBI) series, "Byggedetaljer," which literally translated means "building details." It is hoped that Alaskan builders will be able to glean useful ideas from these publications. The translations were done by Dr. Nils Johanson and Richard D. Seifert of the University of Alaska Fairbanks with the cooperation and permission of NBI, Oslo, Norway. The financial support for the translations and printing came through the Alaska Department of Community and Regional Affairs, from USDOE Grant DE-FG06-80CS6908. The publications use the original index code of the Norwegian "Byggedetaljer" series so that specific translations can be directly cited. All questions on these translations should be directed to Richard D. Seifert, Cooperative Extension Service, P.O. Box 756180, University of Alaska Fairbanks, Fairbanks, Alaska 99775-6180. Phone: 907-474-7201

0 GENERAL

- 01 This bulletin shows how insulation should be added to wood walls to improve their thermal efficiency. Advice is given on the uses of various insulation methods and U values (heat transmission coefficient) with the alternative insulation thicknesses.
- 02 Adding insulation to wood buildings with poor thermal insulation (high U value) will reduce the heating cost and provide a more comfortable indoor environment. Insulation of external walls should always be considered along with insulation of the floor and roof and improvement or replacement of poor windows. It is especially important to stop air leakage, which in older houses is often concentrated between wall and floor, the wall and attic, and around windows. The method of insulating and the thickness of insulation depends on climate, construction type, architectural demands, need for replacement sheathings, the historical value of the building, and the surrounding buildings.
- 03 Older walls are, as a rule, not constructed in the same manner as are modern walls (Figure 03). Additional insulation must, therefore, be fitted to the existing wall framing and coordinated with other improvements to obtain the desired end product. To avoid damage to walls or poor results from retrofitting insulation, it is important to realize that the additional insulation and subsequent sealing of air leaks will alter the temperature conditions within the wall. Parts of the wall that were warm before may now

be cold, and condensation problems can develop. The danger for condensation is greatest in rooms with high relative humidity, such as bathrooms, kitchens, or rooms with different heating systems or insufficient insulation. In houses with good ventilation and relatively low humidity the danger of condensation is small. With the addition of mineral wool insulation, the existing cladding will be colder than before. This can lead to a greater tendency for paint to peel, especially in areas where the weather is severe.

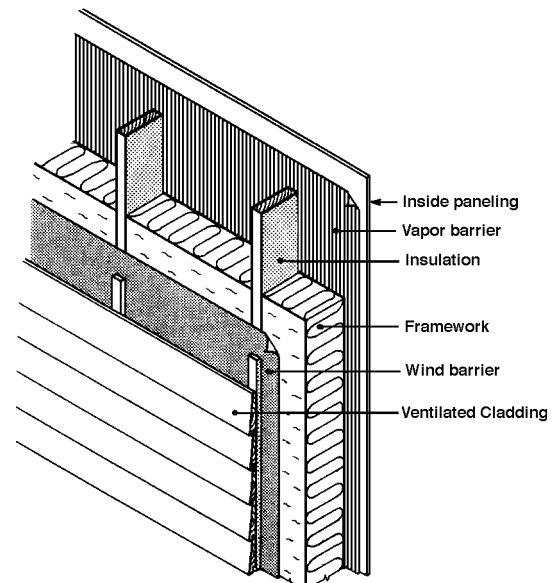

Figure 03
Correctly constructed frame wall of wood.

1 Materials

11 Wood materials

The wood must be dry, straight and without cracks. Wood that will be subjected to humidity for longer periods should be impregnated with a wood preservative.

12 Thermal insulation

Use boards or matts of mineral wool, which is composed of either glass fiber or rock wool. There are two product groups of this type of insulation.

Mineral wool	Density kg/m ³		Conductance (w/m K) according to NS 3031
	Glass wool	Rock wool	
Group A	21	33	0.040
Group B	15	25	0.045

The standard width, 570 mm (23 inches), is designed to fit between studs that are 600 mm (24 inches) center to center. The length can vary from 870 mm (35 inches), which fit between nailers and have a center to center distance of 900mm (36 inches), to 1200mm (48 inches) or longer. Standard thicknesses are 2, 3, 4, 6, and 8 inches. Use mineral wool without paper covering.

13 Windbreak

An external air / wind barrier of cardboard or building boards is suggested. (Ed. Note: TYVEK or the equivalent is suggested for exterior air barrier material in Alaska; it is a new product and appropriate to this application.) Material should have an air penetration number less than about $3 \times 10^{-6} \text{ m}^3 / \text{m}^2 \times \text{s} \times \text{Pa}$ (Pa stands for pascals) and a vapor diffusion number greater than about $1 \times 10^{-10} \text{ kg} / \text{m}^2 \times \text{s} \times \text{Pa}$. In addition, the material must, to some degree, resist moisture in the form of free water. The normal prototypes are windproof building cardboard, 12 mm asphalt-impregnated porous wood fiber board with a wind barrier covering, and 9 mm plaster board with impregnated cardboard.

14 Vapor Barrier

A polyethylene sheet can be used as an internal vapor barrier. Regular polyethylene 6 mils thick is recommended to ensure good mechanical strength during the building construction. The polyethylene must extend the full wall height and be tightly sealed to the framing.

2 THERMAL INSULATION AND SEALING

21 Thermal Insulation

Mineral wool must be placed in the hollow spaces between the studs so that it is sealed tightly against all framing (Figure 21). Where standard forms will not fit the framing, the batts should be cut with an

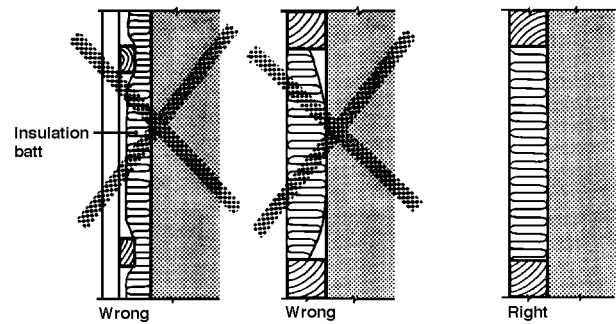

Figure 21
Placement of mineral wool

overlap of 20 mm (0.5 inch) so that they will be somewhat compressed upon installation.

22 Sealing Layer

221 An internal sealing layer (vapor barrier) will prevent moist room air from penetrating into the wall (by air leaks or diffusion) and possibly lead to moisture damage. The vapor barrier must always be on the warm side of the construction. Experience has shown that existing stud walls that are insulated externally or in the stud spaces are normally tight enough without a special vapor barrier because they have interior coverings which suffice. Log walls can be sufficiently tight if they have an external covering and an air barrier. In other cases there must be a tight vapor seal on the warm side of the insulation. When insulation is placed on the inside of the existing walls, follow the same requirements for the vapor barrier as in new construction. The vapor barrier must be sealed tightly around the studs and the joints.

222 An external wind barrier must be installed on the cold side of the insulation. This is to prevent cold air from penetrating into or behind the insulation. Such air leakage can reduce the effect of the retrofit insulation significantly. It is especially important to make sure that there is a windbreak at the top and bottom of the insulation and wherever there are joints. When using internal retrofit insulation, the older, outside wall is the wind and weather barrier. However, where older parts of the building join there can be air leaks. Log walls are subject to leaks in general. Log or old walls should be covered with an extra layer of air barrier to improve air tightness.

23 Joint Sealing

When the wall becomes warmer and tighter, the effect of air leaks around window frames and around the floor and ceiling will be more prominent. When retrofitting insulation, one should seal leaky joints with a good quality sealant. When sealing leaks, it may be necessary to move floor and ceiling molding and even open other parts of the structure to find their source.

3 EXTERNAL INSULATION

31 General

When it is necessary or desirable to repair a wall or when maintenance of a structure is becoming too expensive, conditions are right for external retrofit insulation. An advantage of external insulation is that it is continuous for the height of the wall, thus eliminating and cold bridges. In addition, external insulation does not rob the usable interior space. Using external insulation, however, presents certain challenges. The appearance of the building should not be altered more than necessary. In order to maintain the original appearance select new paneling or covering which is as close to the old one as possible. Windows should be moved out in the wall so that the original window framing can be used. Other design details such as horizontal waterboard, corner boxes and ceiling edges should be copied as closely as possible. External cladding should be vented to the outside using either horizontal or vertical panels. U values are shown in Table 31.

Table 31
Approximate U-value ($W/m^2\text{C}$) for different alternatives for retrofit insulation

Existing structure		Thickness of mineral wool Insulation (mm)			
		50	75	100	150
Log wall	0.9-1.2	0.4-0.5	0.35-0.4	0.3-0.35	
Old timber frame					
m/2 layer cardboard and 2 layer panel on each side	0.9	0.4	0.35	0.3	0.25
Old timber frame m/reflective coated cardboard	0.7	0.4	0.35	0.3	0.25
Newer frame Structures with 100 mm mineral wool insulation	0.45	0.25			

32 Log wall

Any old, external paneling should be removed before adding insulation in order to prevent cold air from penetrating behind the new covering. On a log wall, first install building cardboard with compressed joints. Place the mineral wool insulation between vertical (center to center 600 mm) or horizontal (center to center 600 or 900 mm) nailers. If exterior insulation is used, a layer of building cardboard with pressed joints or air barrier sheets should be installed. There must be a good seal between the lowest nail fastener and the existing wall. If there is internal cardboard or a polyethylene vapor barrier on the inside of the wall, the mineral wool can be placed directly against the timber without the cardboard layer in between (Figure 32).

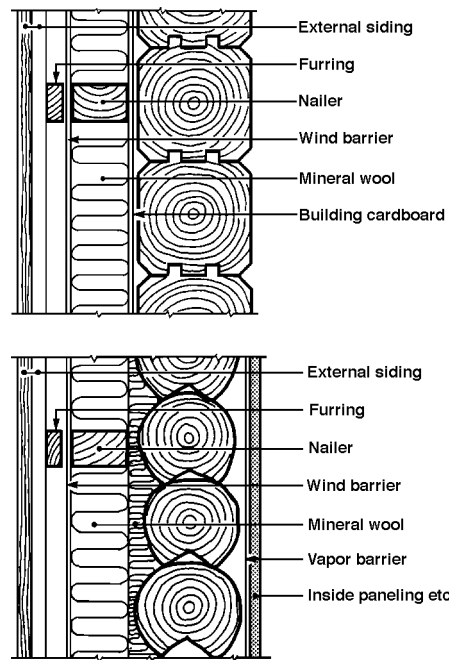

Figure 32
External insulation of log wall
a) With external siding
b) With internal cardboard and paneling

33 Old framework buildings (this is a construction method prior to timber frame, see drawing)

On frame walls that have external paneling against a hollow space of about 50 mm but that have no cardboard in between to prevent cold air infiltration, the paneling must be removed when adding insulation. Install nailers horizontally or vertically depending upon whether horizontal or vertical paneling will be used. The mineral wool can be placed directly against the old cardboard in the wall. Outside the insulation, install retrofit paper cardboard or wind-tight boards with pressed joints (Figure 33).

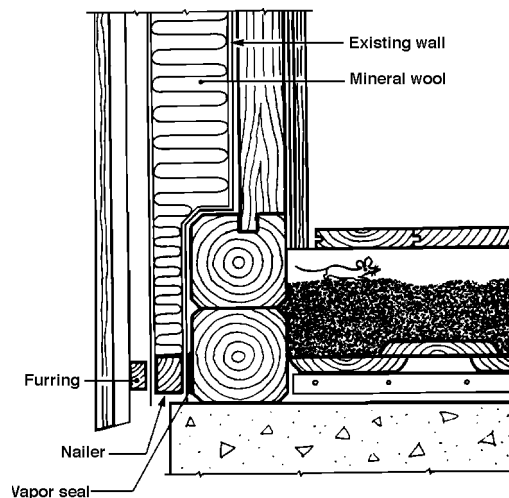

Figure 33
External retrofit insulation of frame wall (Reisverk)

34 Timber framework (Bindingsverk, see Figure 34a)

For external insulation of older masonry framework, consider blowing in mineral wool. See Point 52. In older types of wood-reinforced construction it may be advantageous to remove the outer paneling to get a smoother surface and a better seal at the top and bottom of the wall. Bearing beams can be installed horizontally (center to center 900 mm (3 ft) or 600 mm (2 ft)) or vertically (center to center 600mm (2 ft)), depending upon whether the external covering will be horizontal or vertical. After insulation, install a cardboard cover with compressed joints or wind-proof boards. Ensure that cold air cannot penetrate behind the insulation. The seal between the upper and lower nailer and the old covering is especially important (Figure 34A).

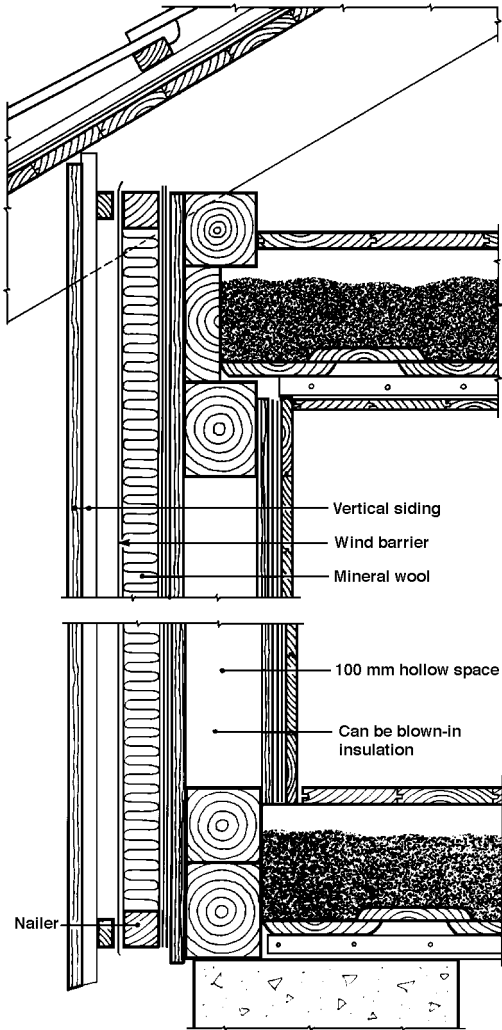

Figure 34a. Externally installed insulation in an older frame wall (bindingsverk) with hollow spaces

In areas where the weather is severe or cold, it may be necessary to add additional insulation to frame-reinforced construction on newer buildings with 100 mm (3.5 in) mineral wool insulation. If so, the old covering and the external cardboard should be removed before installing new nail fasteners and new insulation. A new wind barrier must also be carefully installed (Figure 34b).

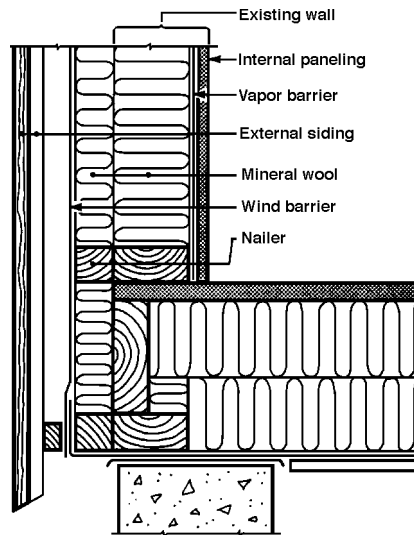

Figure 34b. Retrofit insulation of a newer type frame wall

35 Windows

As a general rule, when retrofitting external insulation the windows should be placed in the same relative position in the external paneling as they were in the original wall so that the window details can be maintained. This is shown in principle in Figure 35a. Figure 35b shows a design where the windows remain in place.

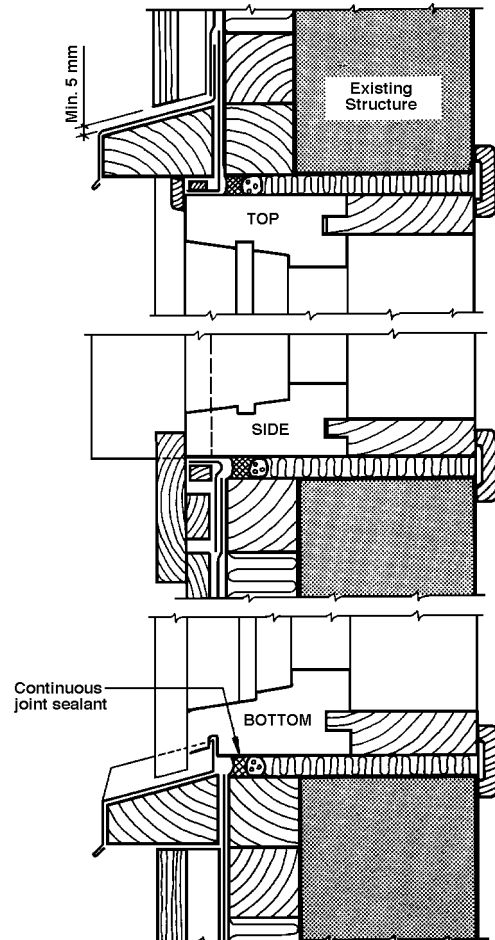

Figure 35a. Detail where the window is moved outward.

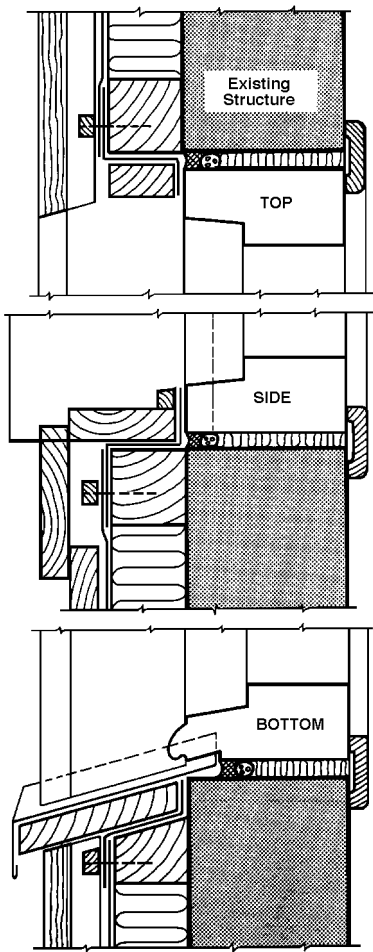

Figure 35b. Details around an existing window when external insulation is added.

4 INTERNAL INSULATION

41 General

Internal insulation is especially desirable when the external condition of the walls or the exterior style has a high value and must be preserved. It may also be desirable when only certain walls need insulating. The disadvantage of internal insulation are that cold bridges and air leaks over the floor, beams, and walls cannot be eliminated and that the internal square footage will be reduced. It may also be necessary to alter window frames and replace installations such as the electrical wiring and plumbing. If there is a hot water central heating system, retrofit insulation will save on heating costs. Retrofitting with interior insulation is easier if the house is unoccupied during reconstruction. U values are shown in Table 31.

42 Execution

Mineral wool is placed between the nail fasteners and installed horizontally or vertically depending on what kind of covering is used. On the interior, install a vapor barrier against the joints and adjoining construction. It is very important that the vapor barrier is airtight and well sealed. Against a log wall, install a cover of cardboard with compressed joints (Figures 42a and b). When insulating a newer wall (with 100 mm mineral wool insulation) on the inside, the existing covering and vapor barrier must be removed first.

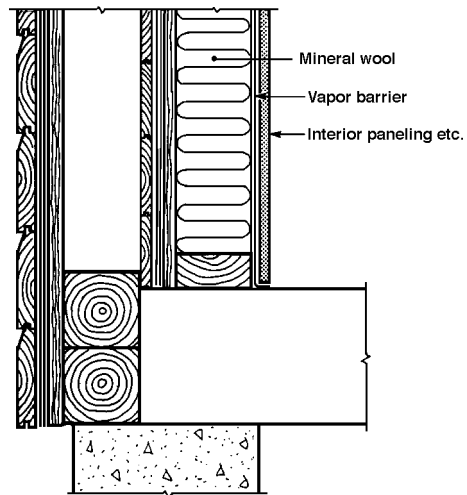
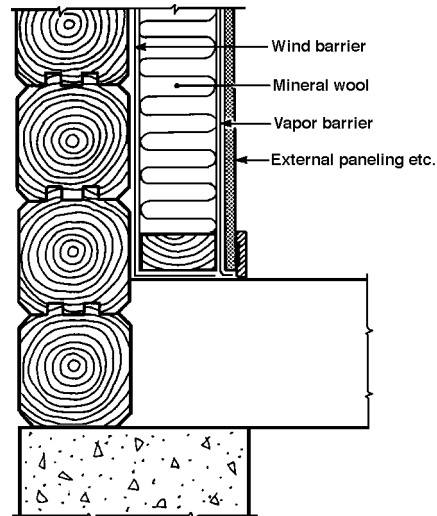

Figure 42a and b
Retrofit insulation applied from the inside
a. against log wall
b. against frame wall of Bindingsverk or Reisverk.

43 Windows

When adding interior insulation, ensure that the vapor barrier is sealed tightly around the window (Figure 43).

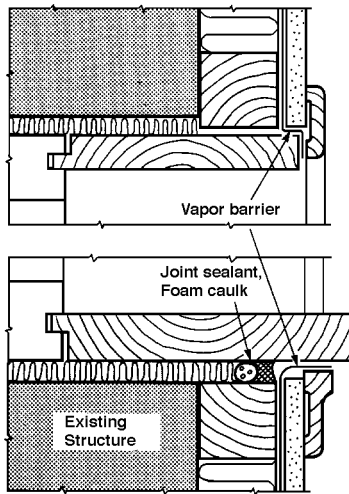

Figure 43
Example of sealing around a window when retrofitting

5 INSULATION OF HOLLOW SPACES

51 General

Insulating the hollow spaces in older outer walls can improve a structure with minimal changes in its construction. Hollow spaces can be filled by blowing granulated mineral wool through a hole in the covering or by removing the covering and reinstalling it after insulation with boards or batts of mineral wool. The advantage of the latter method is that a tight layer can be installed. Polyurethane foam can be injected into wooden walls, however, practical experience shows that it is difficult to measure the amount of foam correctly. This may lead to shrinkage (the foam does not fill the volume completely) and rot and paint damage from water and the insulation chemicals in the wall. U values are shown in Table 31.

52 Pneumatic placement of mineral wool

There have been good results with the pneumatic placement of mineral wool in frame walls. However blown granulated mineral wool can only be used in frame walls where the hollow space is not filled with other insulation materials. Do not blow mineral wool into the hollow spaces between the log wall and external paneling since this prevents drying of the log wall and causes rot. For the same reason, use care when blowing insulation into hollow spaces in walls where there is danger of heavy direct rain. Mineral wool can be blown in from the outside or the inside. Pneumatic placement from the outside is more suitable if the frame wall has an external underpanel and the boards in the outer panel can be taken off without damage (Figures 52 a and b). It is necessary to drill through both panel layers, and there are strict requirements for re-sealing the

holes. The advantage of blowing insulation into existing construction is it requires little alteration of the structure. Pneumatic placement of mineral wool can also be done from the inside by drilling directly through the internal paneling. After filling the hollow spaces, a new vapor barrier and new internal paneling must be installed (Figure 52c). Frame walls are sometimes divided in many areas (Figure 52d, Norwegian style of carpentry). In such cases, granular mineral wool must be blown in by special companies and responsible professionals who know how the wall is constructed.

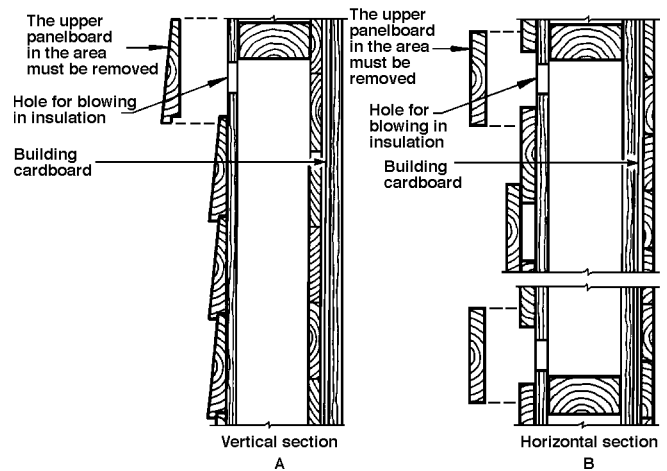

Figure 52 a and b
Holes from the outside for pneumatic placement of mineral wool in houses with horizontal and vertical siding boards.

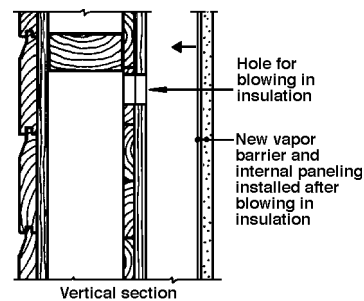

Figure 52c
Drilling of holes from internal side for blowing in mineral wool.

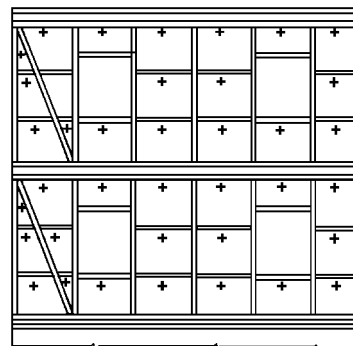

Figure 52d. Side view of older bindingsverk
+ shows where holes must be made for pneumatic placement of granular mineral wool.

53 Insulating hollow spaces installed from the inside

This method can be used in all frame walls that need new interior paneling. After placing mineral wool in the hollow spaces, a new vapor barrier is installed. It must be tightly sealed to the joints before the new paneling is installed (Figure 53).

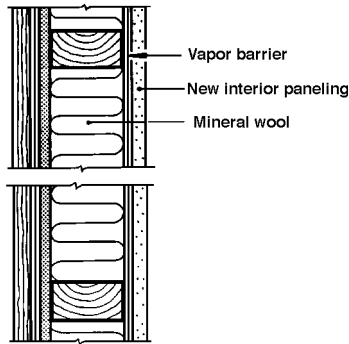

Figure 53
Insulation in frame wall placed from the inside

54 Insulating hollow spaces from the outside

This method is suitable for framework walls and walls where the external paneling and cardboard will be replaced. Elastic mineral wool is placed in the hollow space in the wall, and building cardboard or wind-tight boards are mounted externally with tight joints. With extra space between the cardboard and the paneling it is possible to obtain a greater thickness of insulation (see Points 33 and 34. New external paneling must be ventilated to the outside (Figure 54).

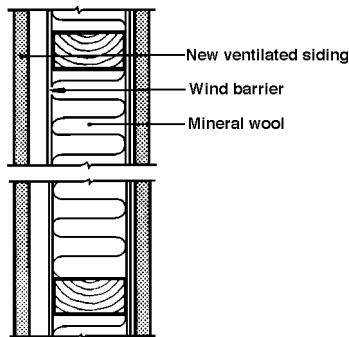

Figure 54
Insulation of frame wall placed from the outside.

6 REFERENCES

- 61 This bulletin is edited by Knut I. Edvardsen. It replaces the bulletin with the same number published Fall 1977. The editorial process was completed April 1983.

English translation by Dr. Nils Johansen and Richard D. Seifert, University of Alaska Fairbanks, Fairbanks, Alaska 99775. July 1989.

A related publication specifically for marine climates has also been translated by Cooperative Extension Service, and is available through extension offices or on the website:

www.uaf.edu/coop-ext/faculty/seifert/

It is entitled *Exterior Ventilated Cladding*, publication number HCM-01558.

Visit the Cooperative Extension Service website at
www.uaf.edu/ces
and Rich Seifert's homepage at
www.uaf.edu/coop-ext/faculty/seifert

8/91/RS/500

Reprinted April 2006



UNIVERSITY OF ALASKA
FAIRBANKS

College of Rural Alaska

Cooperative Extension Service

The University of Alaska Fairbanks Cooperative Extension Service programs are available to all, without regard to race, color, age, sex, creed, national origin, or disability and in accordance with all applicable federal laws. Provided in furtherance of Cooperative Extension work, acts of May 8 and June 30, 1914, in cooperation with the U.S. Department of Agriculture, Anthony T. Nakazawa, Director, Cooperative Extension Service, University of Alaska Fairbanks.

The University of Alaska Fairbanks is an affirmative action/equal opportunity employer and educational institution.